

ROBOOTER

ROBOOTER E60

instruction manual



Shanghai Bangbang Robotics Co., LTD.

Dear users:

Thank you for choosing the electric wheelchair of Shanghai Bangbang Robotics Co., LTD. Robooter E60 Product Manual is an important document that provides the product information, operation methods and after-sales service information of the electric wheelchair. Before use, please carefully read Robooter E60 Product Manual for correct operation and maintenance. This manual contains information protected by patent rights and copyright. Do not copy the content either partially or completely without the written permission of Shanghai Bangbang Robotics Co., LTD. The contents of this manual are subject to change without prior notice. For the latest information on the equipment, please visit the Robooter website.



CONTENTS



1.Safety precautions



2.Product introduction



3.Part introduction
of the electric wheelchair



4.Use of the
electric wheelchair



5.Maintenance and
troubleshooting



6.mobile app operation
guide of the electric
wheelchair



7.Disclaimer



8.Packing list



9. Marking description

1.1 Symbol description



Warning

- The text contents with this symbol mean that, in case of being ignored, there may be serious injury.



Notes

- The text contents with this symbol mean that, in case of being ignored, there may be slight or moderate damage or material damage.

1.2 Intended Use / Indication / Contraindication /Clinical Benefits

- The electric wheelchair is designed for indoor and outdoor use on moderately uneven surfaces and moderate slopes. It is capable of overcoming distances and obstacles in various outdoor environments. Maximum load capacity 150 kg. Suitable for users 155-185cm body height.
Healthcare professionals and lay persons.No professional supervision required.
- User qualification :No professional supervision required - lay persons can use independently.
- Indication: Significant or substantial impairment of mobility/walking due to structural and/or functional damage to the lower extremities (including amputation, injury sequelae, musculoskeletal/neuromusculoskeletal-related movement disorders)
 - In cases of significantly impaired strength and grip function of the arms/hands
 - With sufficient orientation and coordination abilities
- Contraindication: The use of the electric wheelchair is unsuitable for people with severe balance disorders, with severe impairments of cognitive abilities, disorientation, with reduced and inadequate vision, and with impaired perception.
- Clinical Benefits:
 - Improved mobility and independence
 - Enhanced quality of life
 - Accessibility benefits for daily activities

1.3 People unsuitable for using this product

Warning

- Contraindications: This product must not be used by individuals with mental impairments, including those who have temporarily or permanently impaired attention or judgment.

1.4 When to Consult a Healthcare Professional

- Users should consult a healthcare professional in the following circumstances:
Before first use if you have:
 - Any cardiovascular conditions
 - Recent surgery or injury affecting mobility
 - Progressive neurological conditions
 - Uncertainty about your ability to safely operate the electric wheelchair
- During use if you experience:
 - Sudden deterioration of balance or coordination
 - Dizziness or disorientation while operating
 - Any falls or near-falls while using the device
 - Changes affecting your ability to safely control the electric wheelchair
- For professional assessment of:
 - Appropriate seating position and adjustments
 - Need for additional safety accessories
 - Changes in mobility requirements

1.5 Precautions for electrical safety

Notes

This electric wheelchair has passed the test in accordance with ISO 7176-9 Climatic Test.

- This test ensures that the users or escorts of the electric wheelchair have enough time to move the electric wheelchair from the rain to a safe place;
- Do not use or store the electric wheelchair in heavy rain or thunderstorms;
- Do not place this electric wheelchair in a wet place for a long time;
- Do not spray or wash the electric wheelchair with an automatic car wash. If
- Direct exposure to rain, fog, or humid conditions may cause electrical malfunctions, mechanical failures, or corrosion.

1.6 Product use conditions



Notes

- Environmental temperature: -10°C~50°C; Relative humidity: 20%~95%;
- Atmospheric pressure: 70kpa~110kpa; No strong electromagnetic interference.
- The safety belt is used as a safety accessory; it is used to prevent the user from rushing out of the Electric Wheelchair when it stops in operation to ensure the safety of the user.

1.7 Disposal considerations



Notes

- In accordance with local laws and regulations, your product shall be processed separating from the domestic waste. The product shall be recycled in the recycling point designated by local government. The classified collection and recycling of this product facilitate conservation of natural resources.

1.8 Precautions during use

(1) Driving on slopes

This electric wheelchair has passed the test requirements of climbing on a slope of not exceeding 9° with a load of 150kg. Do not try to climb the slopes exceeding 9°.

During reversing on a slope, please be sure to slow down the electric wheelchair. Do not reverse on a slope exceeding 9°. During reversing, please be extremely careful.

(2)The ability of climbing slope and driving distance are affected by battery and following environment:

For example: Weight of the users; Topography (such as grass or gravel); Gradient of hill; Battery life and service life; Extreme temperature; Use and weight of the fittings, etc.

(3) Braking

When the electric wheelchair brakes, please sit down and hold the handrail firmly. When releasing the control joystick, the electric wheelchair will stop within seconds.

Note: Electromagnetic brake will not take effect immediately and will take effect after the wheel rotates.

(4) Emergency braking

In case of critical situation or unexpected movement, press the power switch key to make the electric wheelchair stop (this emergency brake is effective, however, it shall not be used under normal conditions).

Note: Frequent use of emergency brake may make the motor faulty and further prevents the electric wheelchair from being normally used.

(5) Use of mobile phone

Do not drive the electric wheelchair using the mobile app at any time. Please pay attention to road condition when you driving. The mobile app only can be used to help patient move electric wheelchair and set parameters, NOT used to drive electric wheelchair.

(6)The Electric wheelchair may not be fixed as a seat in a moving vehicle.

(7)The speed of the whole vehicle will vary depending on the tire pressure, ground, environment and power.

(8)When folding, the electric wheelchair cannot be locked at the 1st angle. Please use the 2nd or higher angles. It must be folded at 2nd angle to fit into the packaging box.

(For models with adjustable backrests only.)

Please follow the traffic rules.

1.9 Specific warnings (please read carefully)

Prohibited Action	Risk Level	Consequence
Using on escalators	Danger	Death/severe injury
Operating under impairment	Danger	Loss of control
Standing during operation	Danger	Fall/tip-over
Carrying passengers	Danger	Tip-over/structure damage
Using as vehicle seat in motion	Danger	Ejection injury
Unauthorized repairs or modifications	Danger	Electric shock/fire
Using unqualified batteries	Danger	Fire/explosion
Driving on slopes exceeding 9°	Danger	Tip-over
Using in vehicle lanes or non-pedestrian areas	Danger	High-speed collision
Operating on slippery surfaces (water/oil/ice)	Danger	Loss of control
Zigzag driving or high-speed sharp turns	Danger	Tip-over
Sharp high-speed maneuvers or reverse	Danger	Tip-over/loss of control
Mounting without engaged brake	Danger	Unintended movement
Unauthorized app installation	Danger	Unauthorized access /system malfunction
Operating when feeling unwell	Caution	Accident
Use without checking fasteners and connectors	Caution	Parts detachment/malfunction
Neglecting surrounding environment	Caution	Collision
Operating without electrical parts inspection	Caution	Short-circuit/malfunction
Using battery/charger without reading instructions	Caution	Device damage/fire risk
Ignoring rollback risk on slopes	Caution	Rollback collision
Disregarding brief rolling before brake engagement	Caution	Unintended movement
Crossing obstacles over 40mm	Caution	Tip-over/structure damage
Operating functions while not seated	Caution	Accidental activation
Feet placement outside pedals	Caution	Foot injury
Leaving remote control enabled when unused	Caution	Unintended operation

1.10 Excerpts from EMC-related guidelines and statements in manufacturer's accompanying documents

EMI Compliance Table(Table 1)

Phenomenon	Compliance	Electromagnetic environment
RF emissions	CISPR 11 Group 1,Class B	Home healthcare environment
Harmonic distortion	IEC61000-3-2 Class A	Home healthcare environment
Voltage fluctuations and flicker	IEC61000-3-3 Compliance	Home healthcare environment

Table 1-Emission

EMS Compliance Table (Table2-5)

Phenomenon	Basic EMC standard	Immunity test levels
		Home healthcare environment
Electrostatic Discharge	IEC 61000-4-2	±8kV contact ±2kV, ±4kV, ±8kV, ±15kV air
Radiated RF EM field	IEC 61000-4-3	20V/m 26MHz-2.5GHz 80% AM at 1kHz 10V/m 80MHz-2.7GHz 80% AM at 1kHz
Proximity fields From RD Wireless communications equipment	IEC 61000-4-3	Refer to table 3
Rated power Frequency Magnetic fields	IEC 61000-4-8	30A/m 50Hz or 60Hz

Table 2-Enclosure Port

1.Safety precautions

Test Frequency (MHz)	Band (MHz)	Immunity test levels
		Home healthcare environment
385	380-390	Pulse modulation 18Hz, 27V/m
450	430-470	FM, ± 5 kHz deviation 18Hz sine, 28V/m
710	704-787	Pulse modulation 217 Hz sine, 28V/m
745	800-960	Pulse modulation 18Hz sine, 28V/m
780		
810		
870		
930	1700-1990	Pulse modulation 217Hz sine, 28V/m
1720		
1845		
1970		
5785		

Table 3 – Proximity fields from RF wireless communications equipment

	Standard	Home healthcare environment
Electrical fast Transients/burst	IEC 61000-4-4	± 2 KV 100kHz repetition frequency
Surges Line-to-line	IEC 61000-4-5	± 0.5 kV, ± 1 kV
Conducted Disturbances Induced by RF fields	IEC 61000-4-6	3V, 0.15MHz-80MHz 6V in ISM bands and amateur radio bands Between 0.15MHz and 80MHz 80%AM at 1kHz
Voltage dips	IEC 61000-4-11	0% U_r ; 0.5 cycle At $0^\circ, 45^\circ, 90^\circ, 135^\circ, 180^\circ, 225^\circ, 270^\circ$ and 315°
		0% U_r ; 1 cycle and 70% U_r ; 25/30 cycles Single phase: at 0°
Voltage interruptions	IEC 61000-4-11	0% U_r ; 25/30 cycles U_r = rated input Voltage

Table 4 – Input a.c. power port

Phenomenon	Basic EMCstandard	Immunity test levels
		Home healthcare environment
Conducted disturbances induced by RF fields	IEC61000-4-6	3V.0.15MHz-80MHz6V in ISM bands and amateur radiobands between 0.15MHz and 80MHz 80%AM at 1kHz

Table 5 – Signal input/output parts port

Cable	Max. cable length, Shielded/unshielded		Number	Cable classification
	Shielded	Unshielded		
AC Power Line	1.8M	Unshielded	1 Set	AC Power
DC Power Line(USB Cable)	0.95M	Unshielded	1 Set	DC Power

Table 6-Cable information

1.11 Reporting of Serious Incidents

- Users and/or patients must report any serious incident that has occurred in relation to this device to the manufacturer or their authorized representative and the competent authority of the country in which the incident happened.

2.1 Product features and functions

The brushless DC geared motor is the core part to drive the electric wheelchair.

- The special upper controller is used to achieve the control of the motor.

Through the independent control joystick operation, it can achieve forwarding-differential turn, low speed reversing and other actions;

- Folding and unfolding action can be realized;
- Automatic shutdown if case of no 30min operation. The mobile app can

select the automatic shutdown time: 30min, no shutdown;

- Cruise control mode: Press "speed ^" button for 3 seconds and enter the cruise control mode. The front control joystick starts the cruise control;

- Novice mode: Click Fn to enter the novice mode. The voice prompts "Enter the novice mode" and the screen displays the novice mode icon. The first and second gears are optional. Speed gear limit 2.

2.2 Main structure of the product

BBR-E60-01/02/05/06

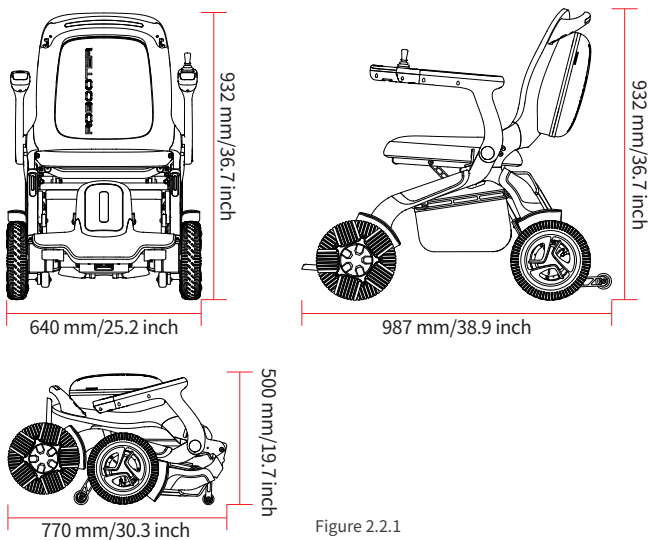

Figure 2.2.1

BBR-E60-03/04/07/08

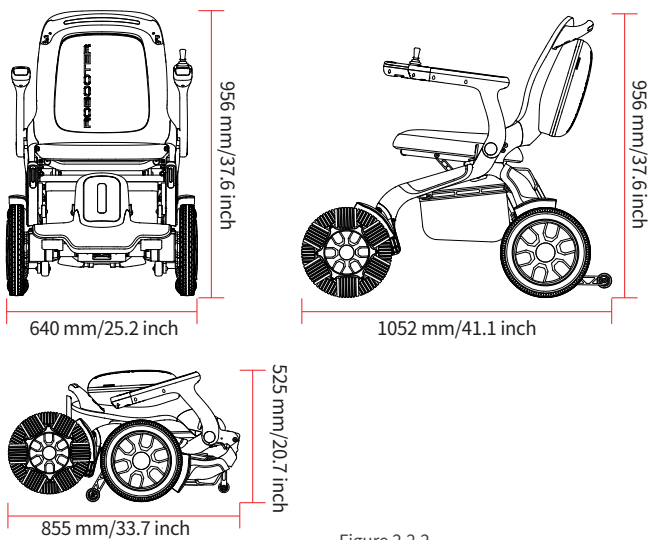

Figure 2.2.2

2.3 Main technical indicators (Kilometer system)

Common name	Electric Wheelchair			
	BBR-E60-01	BBR-E60-05	BBR-E60-02	BBR-E60-06
the type class of the electric wheelchair Class A, Class B or Class C	Class B		Class B	
Front and rear wheel dimensions	10"		10"	
Overall length with largest	987 mm		987 mm	
Overall width	640 mm		640 mm	
Overall height	932 mm		932 mm	
Folded length	770 mm		770 mm	
Folded width	640 mm		640 mm	
Folded height	500 mm		500 mm	
Mass of the heaviest part (without battery)	29 kg		30.8 kg	
Total mass	31.8 kg	32.3 kg	33.6 kg	34.1kg
Battery mass	2.8 kg	3.3 kg	2.8 kg	3.3 kg
Static stability uphill and downhill	15°		15°	
Static stability sideways	6°		6°	
Battery range	25 km (20 Ah)	30 km (25 Ah)	25 km (20 Ah)	30 km (25 Ah)
Dynamic stability uphill	15°		15°	
Obstacle climbing	60 mm		60 mm	
Maximum speed forward	Normal mode: 6 km/h Enhanced mode: 8 km/h		Normal mode: 6 km/h Enhanced mode: 8 km/h	
Minimum braking distance from max speed	1020 mm		1020 mm	
Seat plane angle	3°		3°	
Effective seat depth	430 mm		430 mm	
Effective seat width	420 mm		420 mm	
Seat surface height at front edge	510 mm		510 mm	
Backrest angle	18° (no adjustable)		8-38° (adjustable)	
Backrest height	460 mm		460 mm	
Footrest to seat distance	415 mm		415 mm	
Leg to seat surface angle	100°		100°	
Armrest spacing	480mm (no adjustable)		455-515mm (adjustable)	
Armrest to seat distance	230 mm		230 mm	
Front location of armrest structure	500 mm		500 mm	
Handrim diameter	N/A		N/A	
Horizontal location of axle	103 mm		103 mm	
Minimum turning radius	800 mm		800 mm	
Maximum occupant mass	150 kg		150 kg	
Tyre inflation pressure range	220 kpa-240kpa		220 kpa-240kpa	

Table 2.3

Common name	Electric Wheelchair			
	Product model	BBR-E60-03	BBR-E60-07	BBR-E60-04
the type class of the electric wheelchair Class A, Class B or Class C	Class B		Class B	
Front and rear wheel dimensions	12"		12"	
Overall length with largest	1052 mm		1052 mm	
Overall width	640 mm		640 mm	
Overall height	956 mm		956 mm	
Folded length	855 mm		855 mm	
Folded width	640 mm		640 mm	
Folded height	525 mm		525 mm	
Mass of the heaviest part (without battery)	32.2 kg		34 kg	
Total mass	35 kg	35.5 kg	36.8 kg	37.3 kg
Battery mass	2.8 kg	3.3 kg	2.8 kg	3.3 kg
Static stability uphill and downhill	15°		15°	
Static stability sideways	9°		9°	
Battery range	25 km (20 Ah)	30 km (25 Ah)	25 km (20 Ah)	30 km (25 Ah)
Dynamic stability uphill	15°		15°	
Obstacle climbing	80 mm		80 mm	
Maximum speed forward	Normal mode: 8 km/h Enhanced mode: 10 km/h		Normal mode: 8 km/h Enhanced mode: 10 km/h	
Minimum braking distance from max speed	1020 mm		1020 mm	
Seat plane angle	4.5°		4.5°	
Effective seat depth	430 mm		430 mm	
Effective seat width	420 mm		420 mm	
Seat surface height at front edge	510 mm		510 mm	
Backrest angle	18° (no adjustable)		8-38° (adjustable)	
Backrest height	460 mm		460 mm	
Footrest to seat distance	415 mm		415 mm	
Leg to seat surface angle	100°		100°	
Armrest spacing	480mm (no adjustable)		455-515mm (adjustable)	
Armrest to seat distance	230 mm		230 mm	
Front location of armrest structure	500 mm		500 mm	
Handrim diameter	N/A		N/A	
Horizontal location of axle	103 mm		103 mm	
Minimum turning radius	850 mm		850 mm	
Maximum occupant mass	150 kg		150 kg	
Tyre inflation pressure range	220 kpa- 240 kpa		220 kpa- 240 kpa	

2.4 Storage conditions

- The packaging storage temperature is $-20^{\circ}\text{C}\sim 60^{\circ}\text{C}$;
- The relative humidity is no more than 95%;
- The atmospheric pressure shall be $56\sim 110\text{kPa}$;
- The electric wheelchair shall be stored in the ventilated room without the harmful gas which may cause corrosion, and it is not allowed to press and pile up;
- Under packed status, the maximum piling height is 5 layers.
- Do not make the product stored in the places which get close to high temperature source or direct sunlight for an extended period.
- If the product will not be used for a long term, please store the electric wheelchair is fully charged and power off.
- If the product is stored exceeding one month, please fully charge, and then continue storing and using.

3.Part introduction of the electric wheelchair



Figure 3.1

4.1 Notice for use

- Please carefully read the Product Manual before use and check whether the parts are in good condition to ensure your safety;
- When the electric wheelchair is operated for the first time, level and hard ground shall be selected as soon as possible to ensure that your sounding area has no barrier or pedestrian;
- Do not remove the motor and the upper controller by yourself. If replacement is required, please purchase the original parts from the authorized agent;
- If the electric wheelchair is artificially modified, the use of non-original parts will be exempted from the warranty liability;
- This electric wheelchair must not be used by: a) Persons under 18 years of age (minors), b) Individuals with impaired physical or cognitive abilities that prevent safe operation (see Section 1.3 Contraindications)

Important Clarification: While the minimum user age is 18 years, there is no maximum age limit. Suitability for use depends on individual physical and cognitive capabilities as outlined in Section 1.2 Contraindications, not on chronological age. Elderly users should consult a healthcare professional before first use if they have concerns about their ability to safely operate the wheelchair.

- Do not exceed the maximum load capacity of 150 kg;
Maximum capacity: one person only ;
- Make sure that the electric wheelchair is already fully expanded;
- Make sure that you have fastened the electric wheelchair seat belt;
- When you sit correctly in the electric wheelchair and gently push the control joystick, the electric wheelchair will move forward, back, turn left or turn right; The electric wheelchair will be stopped after the release. Practice this basic function until you are skilled;
- During steering, please clear the barriers nearby;
- Please obey the traffic rules and drive in the non-motorized lane to ensure the safety of you and others. Please drive slowly and Do not take others;
- In challenging environments (e.g., narrow doorways or tight turns), operate the electric wheelchair at reduced speed. It is recommended to minimize to the lowest speed of the electric wheelchair in harsh environments;
- Check whether the electric wheelchair is in good condition, such as whether the performance is normal;
- The electric wheelchair will automatically shut down if being idled for 30 minutes;

- When using an electric wheelchair, avoid being close to a radio transmitter, high-power handheld radio transmitter or receiver;
- Any error or improvement in the Product Manual will be specified in the new specification. We may launch new products to meet the market needs at any time. If there is any difference between the relevant functional description and performance and this manual, the specific products and relevant supplementary instructions shall prevail, and it will not be stated in this manual;

4.2 Expanding and folding of the electric wheelchair

4.2.1 Expanding and folding operation mode

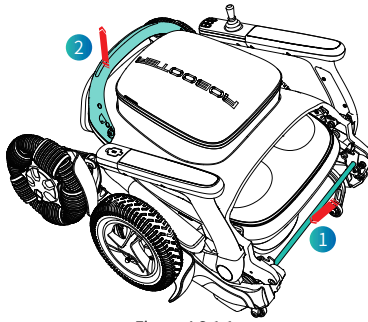

Figure 4.2.1.1

Expanding operation mode: To unfold the electric wheelchair manually: 1. Press the folding release switch (position 1 in Figure 4.2.1.1). 2. Lift the armrest with your other hand (position 2). 3. Continue until the electric wheelchair locks in the fully open position.

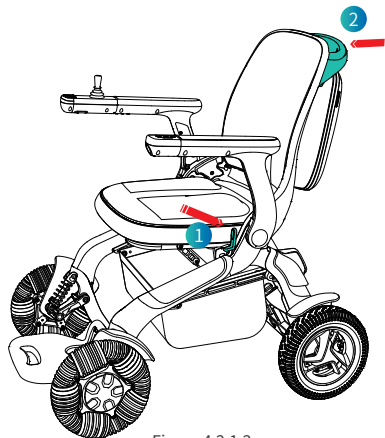

Figure 4.2.1.2

Folding operation mode: When manually folding the electric wheelchair, please press the folding switch with one hand (position 1 in Figure 4.2.1.2) and pull the armrest up with the other hand (position 2 in Figure 4.2.1.2) until the electric wheelchair is fully folded;

Remarks: Before folding the electric wheelchair, empty the items in the storage basket to prevent damage.

4.2.2 Anti-clamp

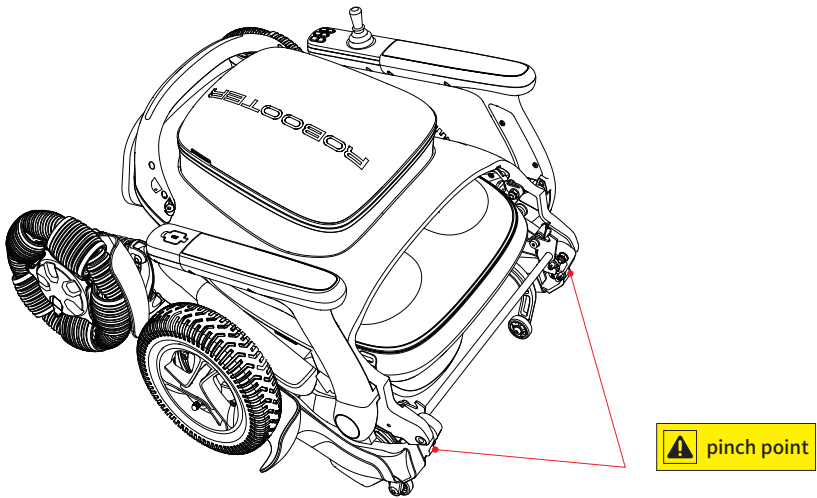

Figure 4.2.2

Note: During the folding/expanding steps, Do not contact the position indicated in the anti-clamp manual;

4.3 Upper controller

4.3.1 Introduction to the upper controller

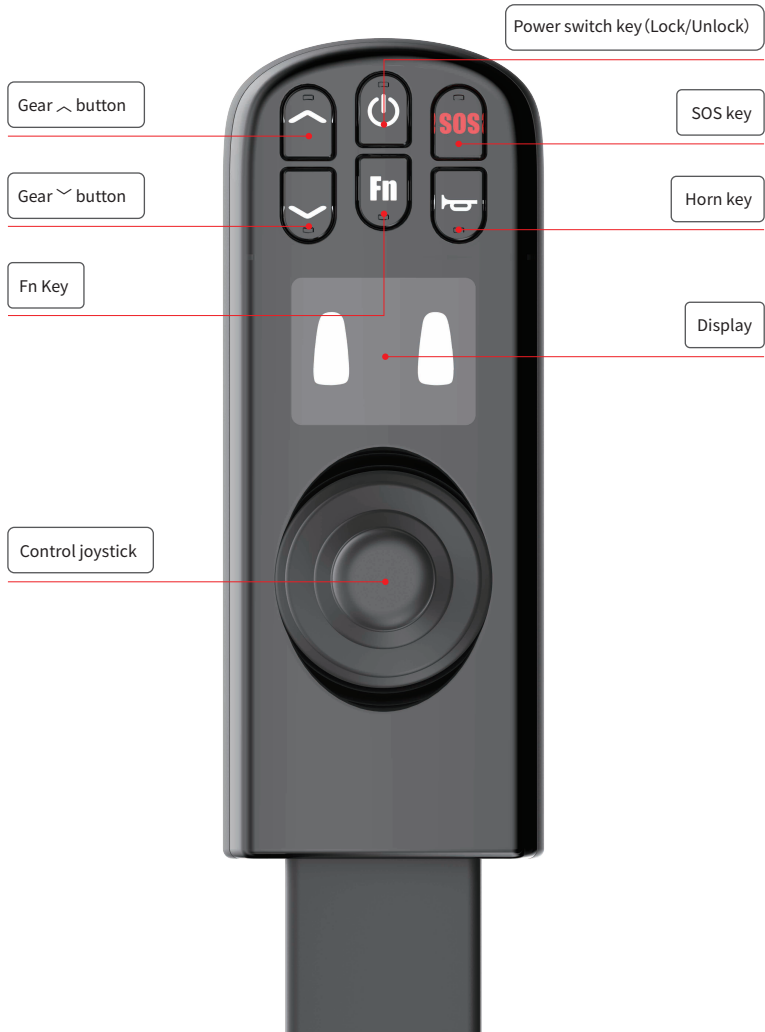

Figure 4.3.1

4.3.2 Function description of the upper controller

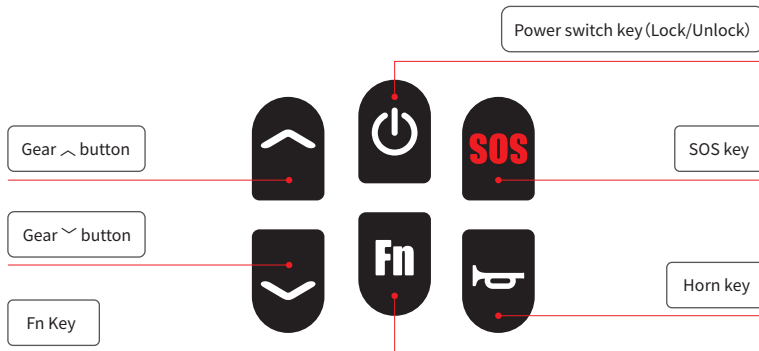

Figure 4.3.2

(1) Control joystick

Pushing the control joystick control joystick can control the speed and direction of the electric wheelchair;

(2) Power switch key

Long press for 3 seconds to turn on the power supply and long press for 3 seconds to turn off the power supply;

Press the power switch key to turn on the vehicle locking function;

Press the power switch key to unlock the entire vehicle, and the current status is unlocked;

(3) Gear ^ button

Press '^' to increase speed (maximum 5 speed levels);

(4) Gear v button

Press 'v' to decrease speed (minimum 1 speed levels);

(5) Horn key

Press the horn button once to sound the horn;

(6) SOS key

Press and hold for 3 seconds to sound the SOS alarm of the electric wheelchair;

(7) Fn key

Click Fn to enter the novice mode, and the screen will display gear 1, gear 2 and the NOVICE icon, accompanied by the voice prompt of "Enter the novice mode". Speed gear limit 2 (the first and second gears are optional).

Long press the Fn key for 5s to enter the General mode, and again long press the Fn key

for 5s to exit the General mode.

When the tyre size is 10 inches: (BBR-E60-01/BBR-E60-02/BBR-E60-05/BBR-E60-06)
In general mode (Figure 5), the Max speed is 6 km/h. In enhance mode (Figure 5), the Max speed is 8 km/h.

When the tyre size is 12 inches: (BBR-E60-03/BBR-E60-04/BBR-E60-07/BBR-E60-08)
In general mode (Figure 5), the Max speed is 8 km/h. In enhance mode (Figure 5), the Max speed is 10 km/h.

4.3.3 Display screen menu description

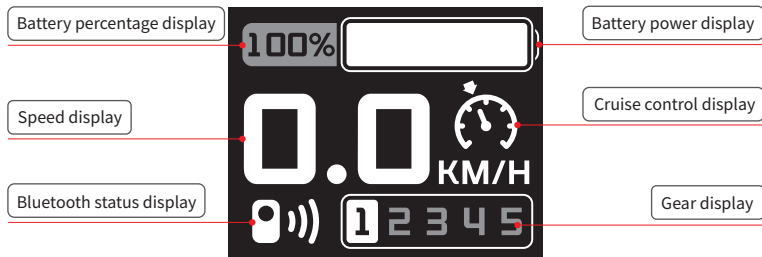

Figure 4.3.3.1

(1) Battery percentage display (as shown in Figure 4.3.3.1)

The upper controller screen of electric wheelchair displays the battery in %;

(2) Speed display (as shown in Figure 4.3.3.1)

The upper controller screen displays the electric wheelchair driving speed (unit: km/h);

The precision of the displayed speed is $\pm 5\%$;

(3) Bluetooth status display (as shown in Figure 4.3.3.1)

Without Bluetooth connection, the Bluetooth indicator sign is not displayed on the screen;

With Bluetooth connection, the Bluetooth indicator sign is displayed on the screen;

(4) Battery power display (as shown in Figure 4.3.3.1)

The upper controller displays the power state in real time;

(5) Cruise control display (as shown in Figure 4.3.3.1)

- Press and hold the "Speed ^" button for more than 3s to enter the cruise control mode. The electric wheelchair upper controller screen displays the cruise control icon, and the voice prompts two times. Push the upper controller forward to start the cruise control;
- Press the lock key or move the control joystick backward to exit the cruise control (regardless of driving state);
- The cruise control function can only be triggered when non-locked, and cannot be triggered in locked mode;
- " ^ " and " ~ " can be used to adjust the gears during the cruise control process;
- Dial the control joystick to control the bending during the cruise control process;
- After entering the cruise control mode, if the cruise control mode is not started within 5s, the cruise control mode will be automatically exited.

(6) Gear display (as shown in Figure 4.3.3.1)

Press ' ^ ' to increase speed (maximum 5 speed levels)

Press " ~ " to decrease speed (minimum 1 speed levels);

The above functions can also be realized on the mobile app.

The electric wheelchair upper controller screen displays the speed gear.

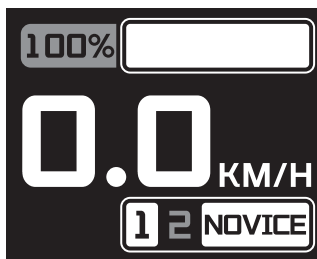

Figure 4.3.3.2

(7) Novice mode display (as shown in Figure 4.3.3.2)

Click Fn to enter the novice mode, and the screen will display gear 1, gear 2 and the NOVICE icon, accompanied by the voice prompt of "Enter the novice mode". Speed gear limit 2 (the first and second gears are optional).



Figure 4.3.3.3

(8) Fault code display (as shown in Figure 4.3.3.3)

For the diagnostic code displayed by the built-in information diagnostor of the product, refer to 5.2 troubleshooting for the content.



Figure 4.3.3.4

(9) SOS display (as shown in Figure 4.3.3.4)

Long press SOS button for 3 seconds to start SOS call. The screen displays SOS icon and flashes.

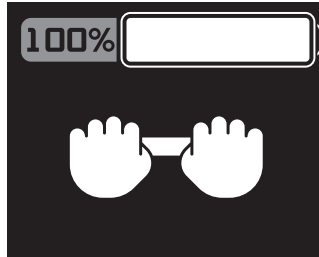

Figure 4.3.3.5

(10) Pushing mode display (as shown in Figure 4.3.3.5)

At the same time, press and hold the button "Speed \wedge " and "Speed \vee " for 3s, and the pushing mode icon will be displayed on the upper controller screen of electric wheelchair.

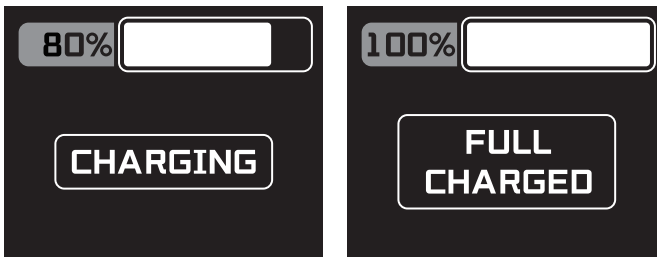

Figure 4.3.3.6

(11) Battery charging status display (as shown in Figure 4.3.3.6)

After the charging port of the electric wheelchair is connected to the charger, the upper controller screen will display CHARGING icon, meaning that the electric wheelchair is being charged;

After the electric wheelchair is fully charged, the upper controller screen will display FULL CHARGED icon, meaning that the electric wheelchair has been charged.

4.4 Usage of armrest touch light and USB charging port

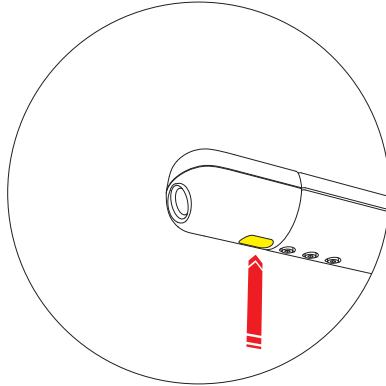

Figure 4.4.1

Touch the touch switch of the lower armrest lamp on the left upper control to control the light on and off of the armrest touch lamp. (As shown on Figure 4.4.1)

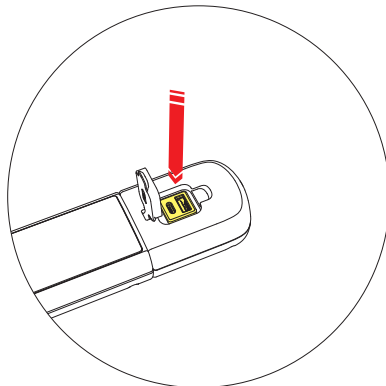

Figure 4.4.2

The armrest touch lamp assembly provides two USB charging ports(USB Type-A, USB Type-C). (As shown on Figure 4.4.2)

4.5 Left and right handrails

4.5.1 Interchangeable operation mode of left and right armrest controllers

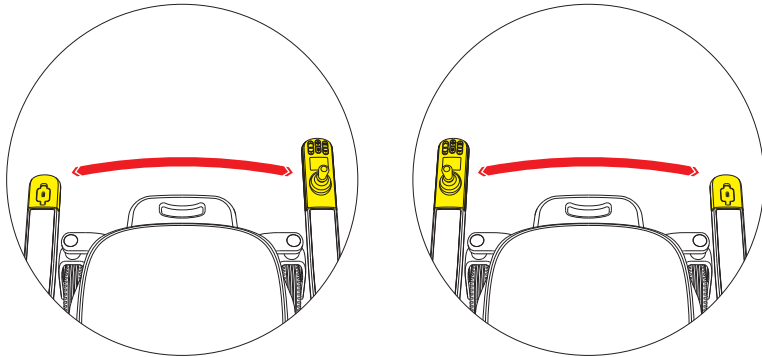

Figure 4.5.1

Step 1, please turn off the machine power before exchanging the left and right armrest controllers.

Step 2, use a hex wrench to remove the three Allen screws under the armrest controller and open the connecting harness of the left and right controllers.

Step 3, interchange the left and right controllers, connect the harness, insert the left and right controllers into the armrest controller card slot, and use the hexagon wrench to lock the hexagon socket screws. (As shown on Figure 4.5.1)

4.5.2 Gear adjustment operation mode of left and right armrest controller

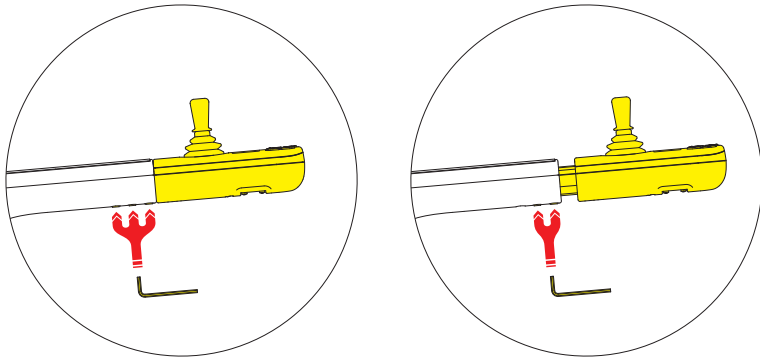

Figure 4.5.2

Step 1, please turn off the machine power before adjusting the gear of the left and right armrest controllers.

Step 2, use a hex wrench to remove the three Allen screws under the armrest controller, and the controller moves outward by one gear.

Step 3, use the hexagon wrench to lock the hexagon socket screw. (As shown on Figure 4.5.2)

4.6 Battery

4.6.1 Battery disassembly

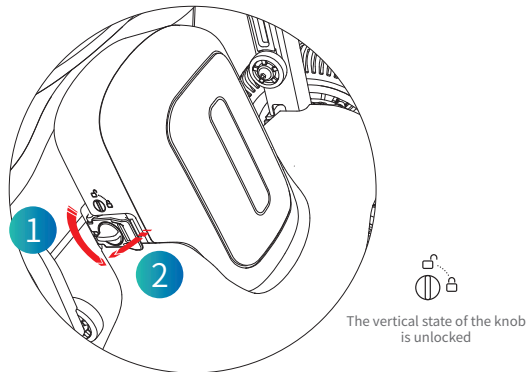

Figure 4.6.1.1

(1) In Step 1, manually rotate the left knob of the battery case and rotate the left knob to the unlocking position. Then open the battery left buckle. (As shown on Figure 4.6.1.1)

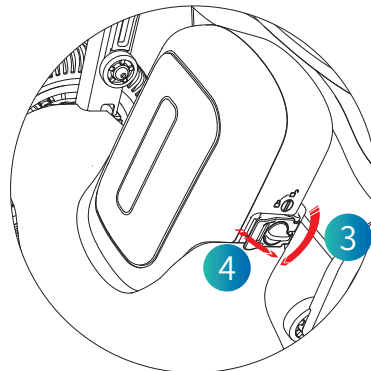

Figure 4.6.1.2

(2) In Step 2, manually rotate the right knob of the battery case and rotate the right knob to the unlocking position. Then open the battery right buckle. (As shown on Figure 4.6.1.2)

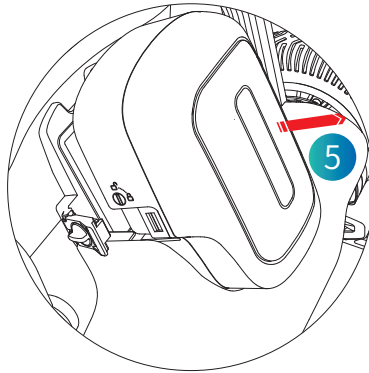

Figure 4.6.1.3

(3) In Step 3, remove the battery in the direction shown in the figure. (As shown on Figure 4.6.1.3)

4.6.2 Battery Installation

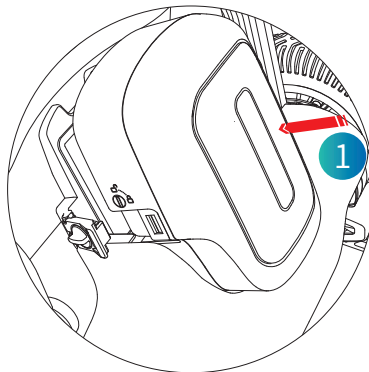

Figure 4.6.2.1

(1) In Step 1, Place the battery in the battery slot in the direction shown. (As shown on Figure 4.6.2.1)

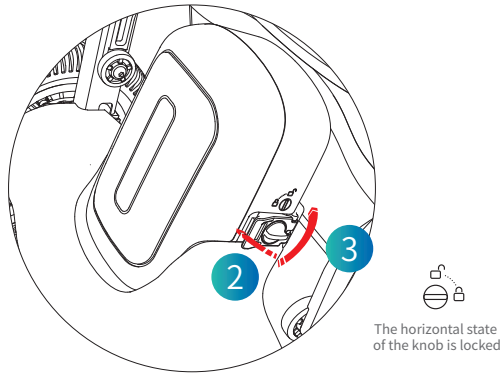

Figure 4.6.2.2

(2) In Step 2, manually close the battery right buckle and rotate the right knob of the battery box with the right knob to the locked position. (As shown on Figure 4.6.2.2)

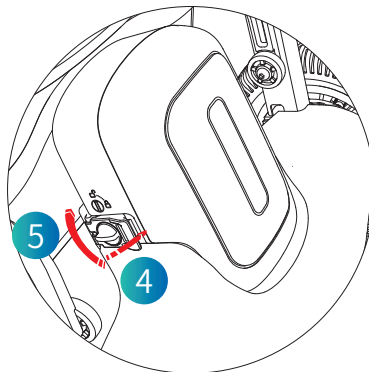

Figure 4.6.2.3

(3) In Step 3, manually close the battery left buckle and rotate the left knob of the battery box with the left knob to the locked position. (As shown on Figure 4.6.2.3)

4.7 Switch to pushing mode

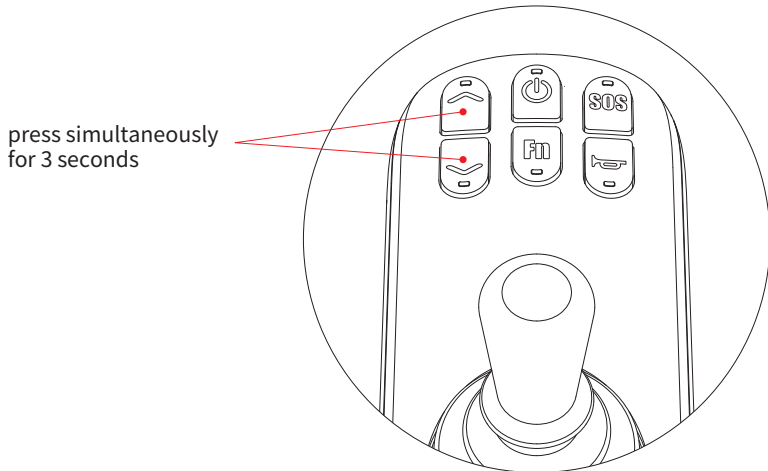

Figure 4.7

Press the speed increase (↗) and speed decrease (↘) buttons simultaneously to activate pushing mode.

Shake the control joystick can exit the pushing mode;(As shown on Figure 4.7)

4.8 Electric wheelchair charging mode

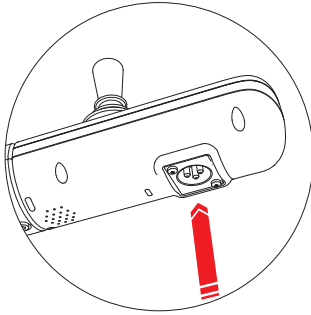

Figure 4.8.1

Charging method I: Connect the charger and plug the charger plug into the upper controller for charging; (As shown on Figure 4.8.1)

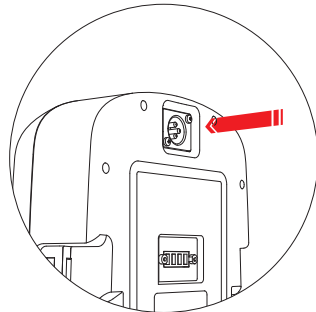

Figure 4.8.2

Charging method II: Take out the battery, plug the charger plug into the charging port of the battery to charge; (As shown on Figure 4.8.2)

4.9 Getting in the device

Accessing the seat from the side

- (1) Ensure the power is turned off.

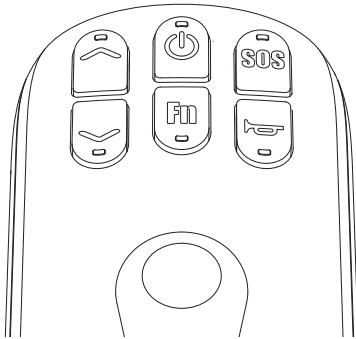

Figure 4.9.1

- (2) Raise the armrest.

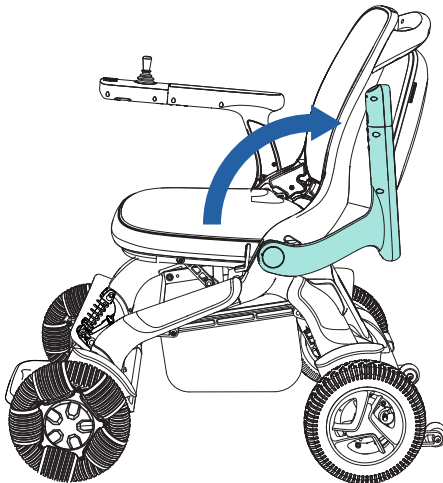

Figure 4.9.2

(3) Raise the footrest with the handle held in hand.

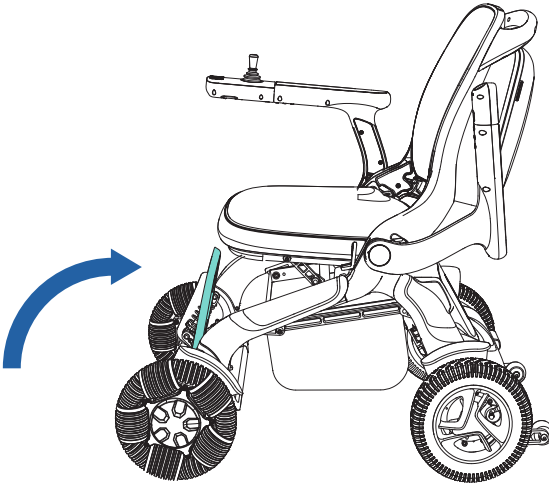

Figure 4.9.3

(4) Sit on the seat.

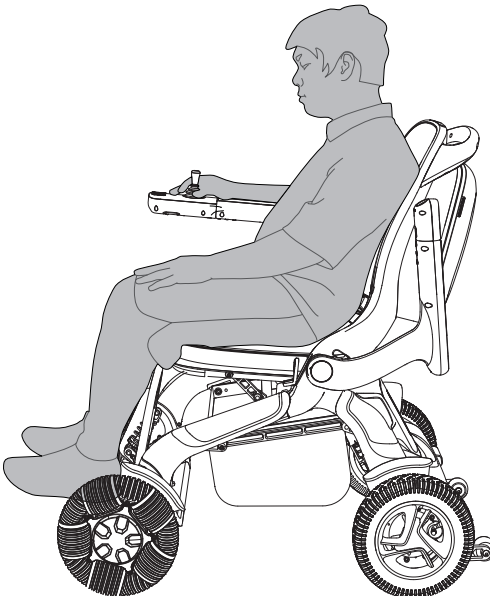
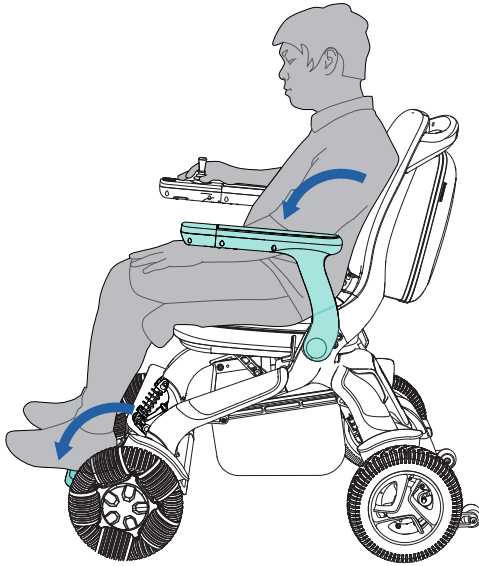
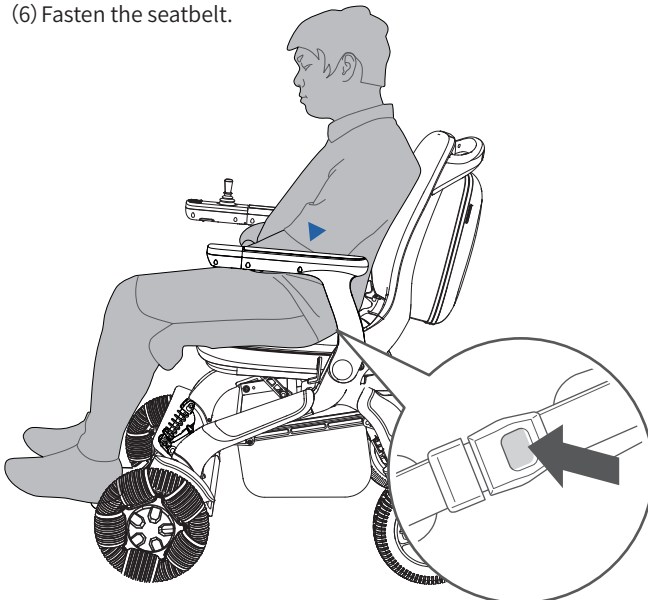

Figure 4.9.4

(5) Rotate the armrest forward.



(6) Fasten the seatbelt.



(7) Booting.

(8) Driving.

4.10 Adjusting Armrest Distance

Loosen the two knobs located below the armrest and adjust to the desired position. Once in the appropriate position, tighten the knobs.

(For models with adjustable armrests only)

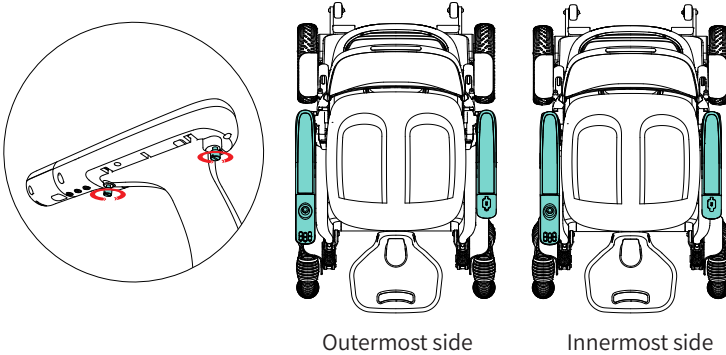

Figure 4.10

4.11 Adjusting Backrest Angle

Pull the two Pin handles vertically backward and adjust to the desired position. Once in the appropriate position, fasten the Pin handles in place.

(For models with adjustable backrests only)

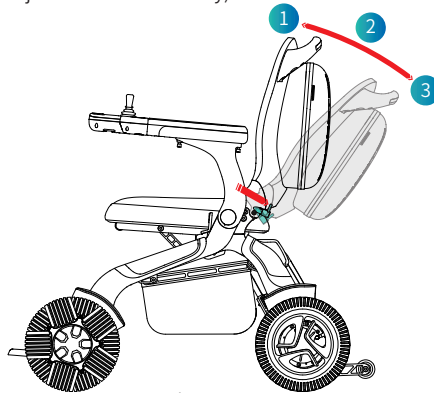

Figure 4.11



When folding for storage, do not lock the backrest at the most reclined position (position 1 in Figure 4.11). Use position 2 or higher. Position 2 is required for the wheelchair to fit in the packaging box.

5.1 Daily spot inspection and maintenance



Warning

- Always turn off power and disconnect battery before inspection

Interval	Task	Performed by
Daily	Visual inspection of overall condition	User
	Battery charge level check	User
Weekly	Check tire pressure and condition	User
	Inspect fasteners for loosening	User
Monthly	Check folding mechanism operation	User
	Tighten all accessible fasteners	User
	Inspect wiring harness connections	User
As Needed	Battery replacement (specify expected lifespan)	Service Personnel
	Tire replacement	Service Personnel

5.2 Performance fault table of the electric wheelchair

Fault code	Anomaly status	Fault phenomenon
E1	Key abnormality	The key corresponding function does not work.
20	The control joystick ground line is disconnected	The control joystick function does not work.
21	The control joystick power cord is disconnected	The control joystick function does not work.
22	The control joystick X-axis is disconnected	The control joystick function does not work.
23	The control joystick Y-axis is disconnected	The control joystick function does not work.
24	The control joystick is a non-zero start	The control joystick function does not work.
E6	CAN communication is abnormal	The control joystick cannot control the driving of the electric wheelchair.
E7	FLASH fault	FLASH device ID cannot be detected and the device cannot work.
82	Left motor Hall fault	The left motor Hall is not connected or faulty, and the motor does not function.
81	Right motor Hall fault	The right motor Hall is not connected or faulty, and the motor does not function.
40	Left motor electromagnetic brake failure	The left motor's electromagnetic brake engages when the brake release handle is released.
41	Right motor electromagnetic brake failure	The right motor's electromagnetic brake engages when the brake release handle is released.
80	Low-voltage fault	The motor cannot run.
88	Pre-charge fault	The motor cannot run.
84	Short-circuit fault of lower gear MOS in the right motor	The motor cannot run.
85	Short-circuit fault of upper gear MOS in the right motor	The motor cannot run.
86	Short-circuit fault of upper gear MOS in the left motor	The motor cannot run.
87	Short-circuit fault of lower gear MOS in the left motor	The motor cannot run.
90	High voltage fault	After detecting the high pressure before starting, keep it locked.
91	The Left motor phase loss and disconnection fault	The motor cannot run.
92	The right motor is out of phase and disconnected	The motor cannot run.
93	The Left motor and The right motor are out of phase and disconnected	The motor cannot run.
94	The Right motor stall	The motor cannot run.
95	The Left motor stall	The motor cannot run.
96	Left and right motors are stuck	The motor cannot run.

Table 5.2

5.3 Consumable Components and Maintenance

Component	Expected Lifespan	Replacement Indicators
Battery	36MONTHS	When the driving range is less than 50% of the normal operating range, the battery requires replacement.
Tires	24MONTHS or 2400KM	The tread pattern is no longer clearly visible.
Brake components	60MONTHS	Unusual noise or malfunction
Roller of omnidirectional wheel	36MONTHS or 3600KM	Unusual noise or wobbling
Cushion	18MONTHS	Damaged
Backrest	18MONTHS	Damaged
Armrest veneer	24MONTHS	Damaged or warped
1.Expected lifespan under normal use 2.Normal use: average daily usage of 4 hours on surfaces appropriate for device class"		

5.4 Instruction of safety warning

Voice prompts	Corresponding scene description.
Enter novice mode	Press the novice mode button.
Quit the novice mode	Press the novice mode button again.
Alert	Long press SOS key to trigger SOS.
LOCK	It is in default that after the product is locked after it is powered on. Switch non-locking status to locking status.
Unlock	Switch locking status to non-locking status.
Start the remote control	Voice prompt when the remote control or mobile app Bluetooth is connected successfully.
Upgrade	When the mobile app detects new version, click to upgrade.
Upgrade complete	End of the single-module upgrade.
Upgrading	The equipment is upgrading.
Key tone	Touch the button to produce a prompt sound.
Charging	Charging
Charging complete	Unplug the charger and trigger the voice prompt of charging completed.
Breaks open	The band-type brake opens.

Bluetooth connected	Voice prompt when the remote control or mobile app Bluetooth is connected successfully.
Drive protection	Voice prompt for a drive failure.
Machine protection	Voice prompt for a machine failure.
Control joystick protection	Voice prompt for a control joystick failure.
Bluetooth disconnected	Voice prompt when the remote control or mobile app Bluetooth is disconnected.
Upgrade failed	There is something wrong during upgrading.
The horn sounds	Touch the horn button.
Low battery, please charge	Trigger when the power is lower than 20%.
Bluetooth unlocking the car	Press the remote control to unlock.
Implementation mode	Long press "∧" button and "∨" button 3 seconds to enter the pushing mode, accompanied by the pushing mode prompt.
Exit implementation mode	Shake the control joystick to quit the pushing mode.

Table 5.3

5.5 Production date and service life

- The service life of this product is 5 years after the product is delivered. Please use within the effective date. In case of expiration, Do not use the product to avoid occurrence of accident.
- Refer to product tag for date of production.

5.6 Cleaning and Disinfection Guidelines

To ensure hygiene, safety, and maintain the optimal condition of your electric wheelchair, please follow these cleaning and disinfection guidelines. Regular cleaning can be performed frequently. Disinfection is recommended after potential exposure to bodily fluids or use in healthcare settings.

1. Routine Cleaning

- Method: Wipe surfaces with a soft, damp cloth (e.g., microfiber) moistened with a mild neutral detergent solution (e.g., diluted dish soap).
- Note: Dry surfaces immediately with a clean, dry cloth after wiping to prevent moisture from penetrating the device's interior.

2. Disinfection

Follow this disinfection procedure when a higher level of microbial control is required. Please perform the routine cleaning steps described above before disinfection.

Component	Recommended Disinfectant	Recommended Disinfectant	Disinfection Level	Important Restrictions
Metal Frame, Plastic Covers, Armrests	70-75% Isopropyl Alcohol Solution	≥ 1 minute	Intermediate-level	Avoid excessive use; allow to air dry after wiping. Frequent use may accelerate aging of plastics or coatings.
Seat Cushions	Quaternary Ammonium Disinfectant	≥ 5 minutes	Low to Intermediate-level	Avoid excessive use; allow to air dry after wiping. Frequent use may accelerate aging of plastics or coatings.
Controller, Touch Display	70% Isopropyl Alcohol Wipes	≥ 1 minute	Intermediate-level	Do not spray alcohol-based cleaners directly onto the screen. Apply the liquid to a soft cloth first, then gently wipe the screen to prevent fluid from seeping into the device.
Tires, Footplates	Diluted Chlorine-based Disinfectant (e.g., bleach solution)	≥ 10 minutes	High-level	Suitable only for these durable components. Wipe thoroughly with a damp cloth and clean water afterwards to prevent corrosion.

General Precautions

- **Prohibited Substances:** Do not use abrasive cleaners, strong acids, strong alkalis, solvents (e.g., acetone, thinner), or corrosive cleaners, as they may damage the device's surfaces and internal structure.
- **Moisture Protection:** Ensure all connection ports and the controller remain dry during cleaning. Never rinse the electric wheelchair directly with water or use high-pressure spray.
- **Ventilation:** Perform cleaning and disinfection in a well-ventilated area and avoid inhaling disinfectant vapors.
- **Personal Protection:** It is recommended to wear rubber gloves during operation.

5.7 Risk Mitigation During Servicing

- For user-performed maintenance (cleaning, basic checks): "Routine maintenance and cleaning can be performed by users following instructions in Section 5.1& Section 5.6. Ensure device is powered off before cleaning."
- For technical servicing (motor, electronics, structural repairs): "Technical servicing and repairs must be performed by manufacturer-authorized service personnel only. Unauthorized repairs void warranty and may create safety hazards. "Contact: [gaoy@bangbangrobotics.com/zhangmq@bangbangrobotics.com]"

Scan the QR code to download mobile app



Install mobile app

(Android)

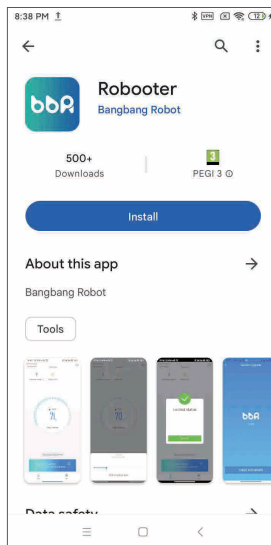

The above screen is displayed after scanning, click **Install** to install the mobile app.

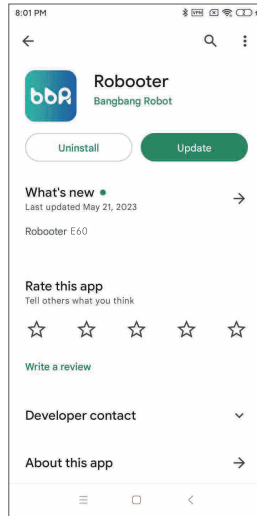

The above screen indicates that the installation of the mobile app is complete.

Click  on the above screen to open the mobile app

(IOS)

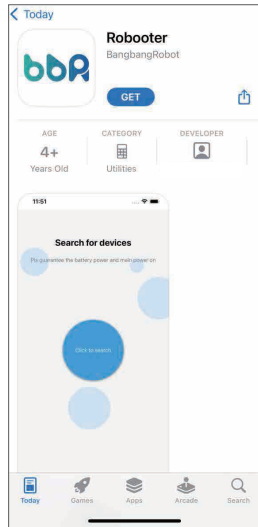

The above screen is displayed after scanning, click **GET** to install the mobile app.

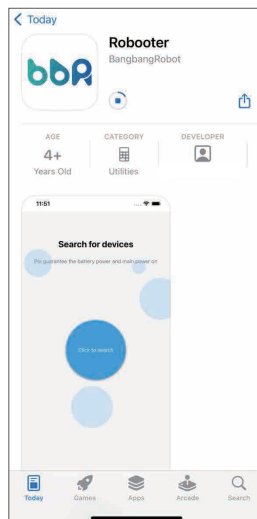

The above screen indicates that the mobile app is being installed

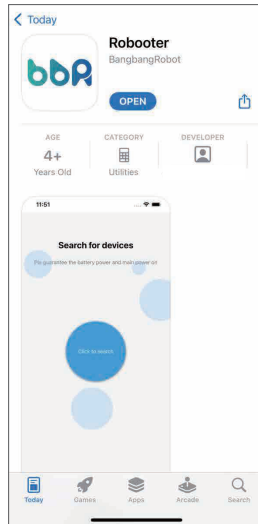

The above screen indicates that the installation of the mobile app is complete.

Click **OPEN** on the above screen to open the mobile app

Connect Device

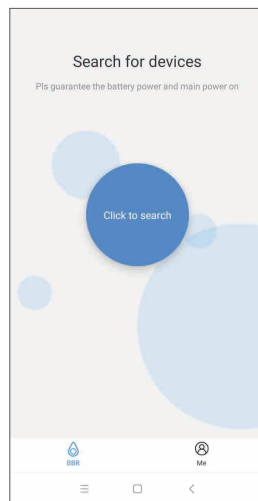

Click **Click to search** on the above screen to search device.

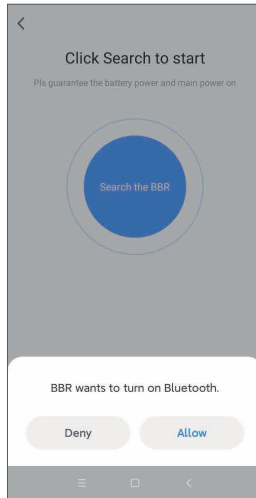

Note: Obtain phone permissions

Click **Allow** on the above screen to turn on your mobile' s Bluetooth

Install mobile app

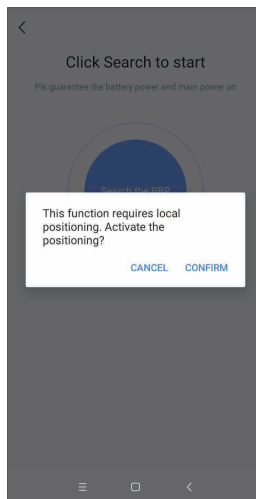

Note: Obtain phone permissions

Click **CONFIRM** on the above screen to turn on your phone's location.

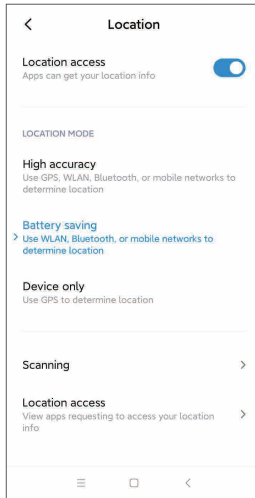

Note: Obtain phone permissions

Click "Location access" on the above screen to turn on your phone's location.

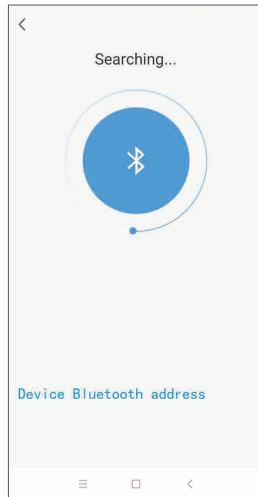

Once the above operation has been done mobile app start searching for the device.

Click `DF:85:EC:73:15:05`  to pair the mobile app and device.

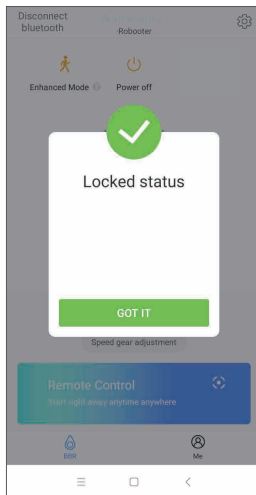

Note:When the electric wheelchair is in lock mode, display this interface. After turning on the electric wheelchair, enter the lock mode automatically. Only use the mobile app after unlocking on the electric wheelchair.

The above screen indicates a successful connection.

Click **GOT IT** in the above screen to access status screen of the electric wheelchair

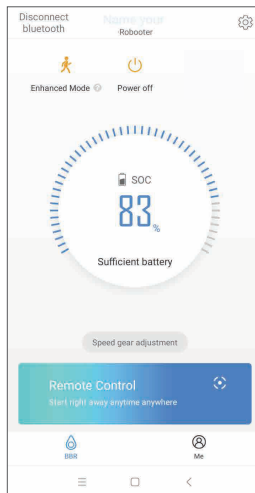

Click  to turn off the device.

Click  to disconnect the bluetooth connection.

Click  to adjust the device speed.(Adjustable speed in 5 gears)

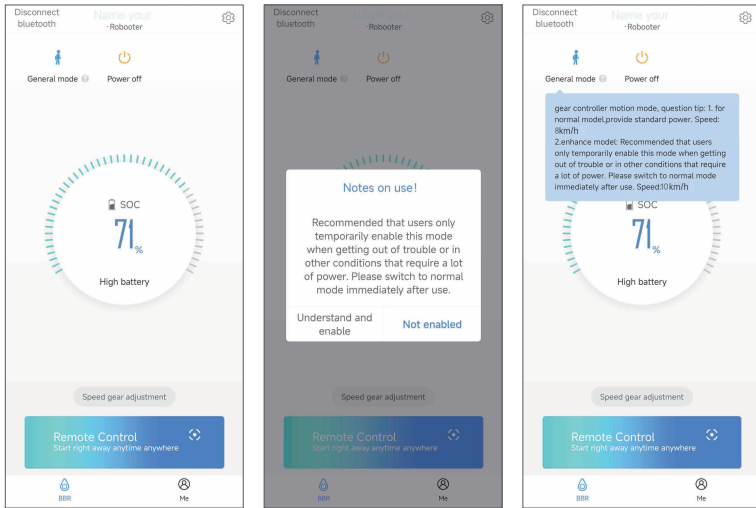

Click  in status screen to access enhanced mode adjustment and general mode adjustment.

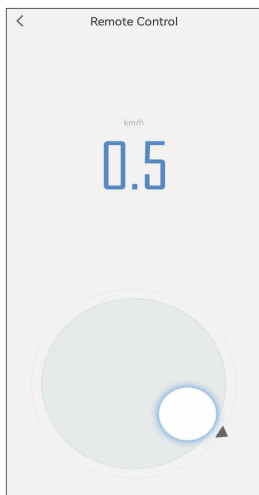

Click **Remote Control** in the status screen to access the remote control mode
Circle up to move forward, down to move back, left to turn left, right to turn right.

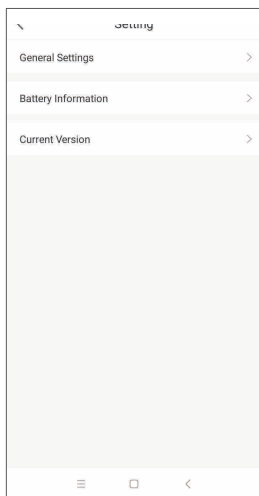

Click  in the top right corner to access the setting screen

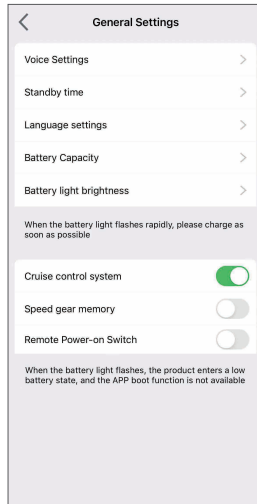

Click "General Settings" in the setting screen to access the general settings mode.
 Cruise control system: slide left to turn off cruise control, slide right to turn on cruise control.

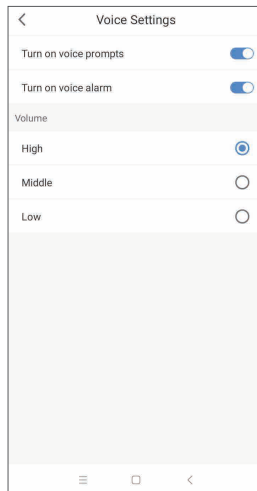

Click "Voice settings" in the General settings to access the voice settings mode.
 Turn on voice prompts: slide left to turn off voice, slide right to turn on voice.
 Turn on voice alarm: slide left to turn off voice, slide right to turn on voice.
 Adjustable 3-step volume: High, Middle, Low.

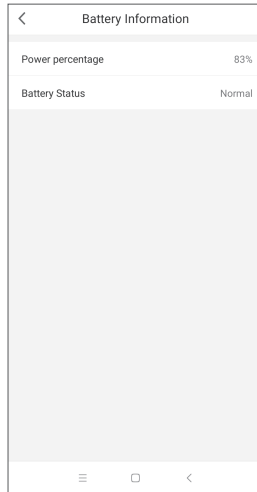

Click “Battery information” in the setting screen to access battery information screen.
Shows battery power percentage and battery status.

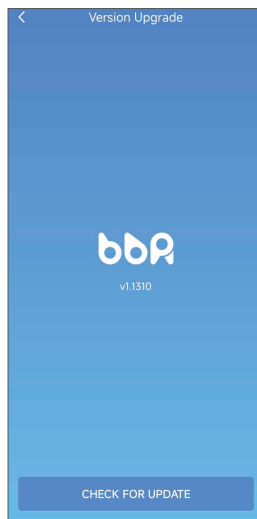

Click “Current Version” in the setting screen to access version upgrade mode.
Show current device version.
Click [CHECK FOR UPDATE](#) to upgrade version of device.

Minimum System Requirements

- Android version 6.0 or higher
- iOS version 9.0 or higher
- Bluetooth version 4.0 or higher
- Minimum RAM: 1 GB
- Required storage space: 50 MB

IT Security Measures

- Only pair the electric wheelchair with your personal smartphone
- Do not enable automatic Bluetooth pairing with unknown devices
- Keep the mobile app and smartphone operating system updated
- Do not use the mobile app on rooted/jailbroken devices
- Connection is encrypted using AES-128
- To prevent unauthorized access: once the mobile app is connected to the electric wheelchair, no other mobile app can establish a connection to it.

Data Privacy and Security

- The mobile app processes only technical device data (battery status, speed settings, diagnostic information).
- No personal health data, user identity information, or location tracking is collected, stored, or transmitted.
- Connection is encrypted using AES-128.
- To prevent unauthorized access: once connected, no other mobile app can establish a connection simultaneously.

The Robooter E60 Instructions for Use are compiled with care to ensure accuracy and completeness in accordance with applicable regulations.

Shanghai Bangbang Robotics Co., Ltd. continuously improves its products.

For the most current information:

Visit our website: www.robooter.com





















Contact your authorized dealer Or contact us directly at [contact information]

Important: If safety-relevant changes occur, we will inform users in accordance with our regulatory obligations under EU MDR (EU) 2017/745. Users will be notified through appropriate channels as required.

This product must be operated in accordance with these Instructions for Use and applicable local regulations. Users or third parties who fail to follow these instructions and operate the device contrary to documented safety warnings assume responsibility for resulting injuries or damages in accordance with applicable law.

S/N	Material name	Unit	Quantity	Remarks
1	Electric wheelchair	Set	1	Included battery
2	Product Manual	Number	1	
3	Charger	Pcs	1	
4	Toolkit	Pcs	1	Including hexagon wrench, open wrench, screw

Table 9

	Manufacturer Indicates the medical device manufacturer
	Date of manufacture Indicates the date when the medical device was manufactured.
	Authorized representative in the European community/European Union Indicates the authorized representative in the European Community/ European Union
	CE MARKING OF CONFORMITY The CE marking shall consist of the initials 'CE' taking the form according to Medical Device Annex EU Regulation 2017/745.
	Serial number Indicates the manufacturer's serial number so that a specific medical device can be identified.
	Batch code Indicates the manufacturer's batch code so that the batch or lot can be identified.
	Medical device Indicates the item is a medical device.
	Use-by date Indicates the date after which the medical device is not to be used.
	The first X represents the lack of testing for solid objects, while the second X indicates the waterproof level of the device.
	Indicates separate collection for waste of electrical and electronic equipment (WEEE).
	Maximum number of identical transport packages/items which may be stacked on the bottom package. where "n" is the limiting number.
	This is the correct upright position of the distribution packages for transport and/or storage.
	Distribution packages shall be kept away from rain and be kept in dry conditions.
	Contents of the distribution packages are fragile, therefore it shall be handled with care.
	Made in China
	Model Number Indicates the model number or type number of a product
	Consult instructions for use or consult electronic instructions for use Indicates the need for the user to consult the instructions for use
	Authorised representative in Switzerland
	Importer Indicates the entity importing the medical device into the locale
	Distributor Indicates the entity distributing the medical device into the locale
	Catalogue number Indicates the manufacturer's catalogue number so that the medical device can be identified



 **Shanghai BangBang Robotics Co., Ltd.**

ADD:Room 501, Building 3, No. 188

Zhongchen Road, Songjiang

District, Shanghai

Tel: 00862137777720

Email: info@bangbangrobotics.com Website:

www.bangbangrobotics.com

EU REP Kingsmead Service B.V

ADD: Zonnehof 36,2632 BE, Nootdorp, Netherland



TEL:0031(0)64657 1005

CH REP SUNGO Technical Service GmbH

Bahnhofstrasse 21,6300 Zug, Switzerland